

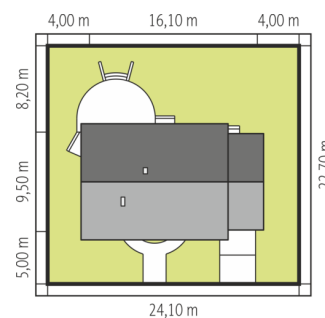

Powierzchnia użytkowa	91.61 m ²
+ garaż	21.60 m ²
Powierzchnia zabudowy	143.82 m ²
Pow. netto	120.09 m ²
Kubatura	321.84 m ³
Wysokość budynku	6.65 m
Kąt nachylenia dachu	30°
<hr/>	
Koszt budowy już od:	0 zł

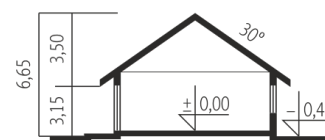

Parter

1. Wiatrołap	1.78 m ²
2. Hol	9.42 m ²
3. Kuchnia	6.75 m ²
4. Spiżarnia	1.51 m ²
5. Pokój dzienny + jadalnia	24.21 m ²
6. Sypialnia	13.36 m ²
7. Sypialnia	9.91 m ²
8. Sypialnia	9.91 m ²
9. Łazienka	6.07 m ²
10. Toaleta	1.37 m ²
11. Pom. gospodarcze	5.30 m ²
12. Pom. gospodarcze	2.02 m ²
13. Garaż	21.60 m ²